

CHF 1064 TOP GAS

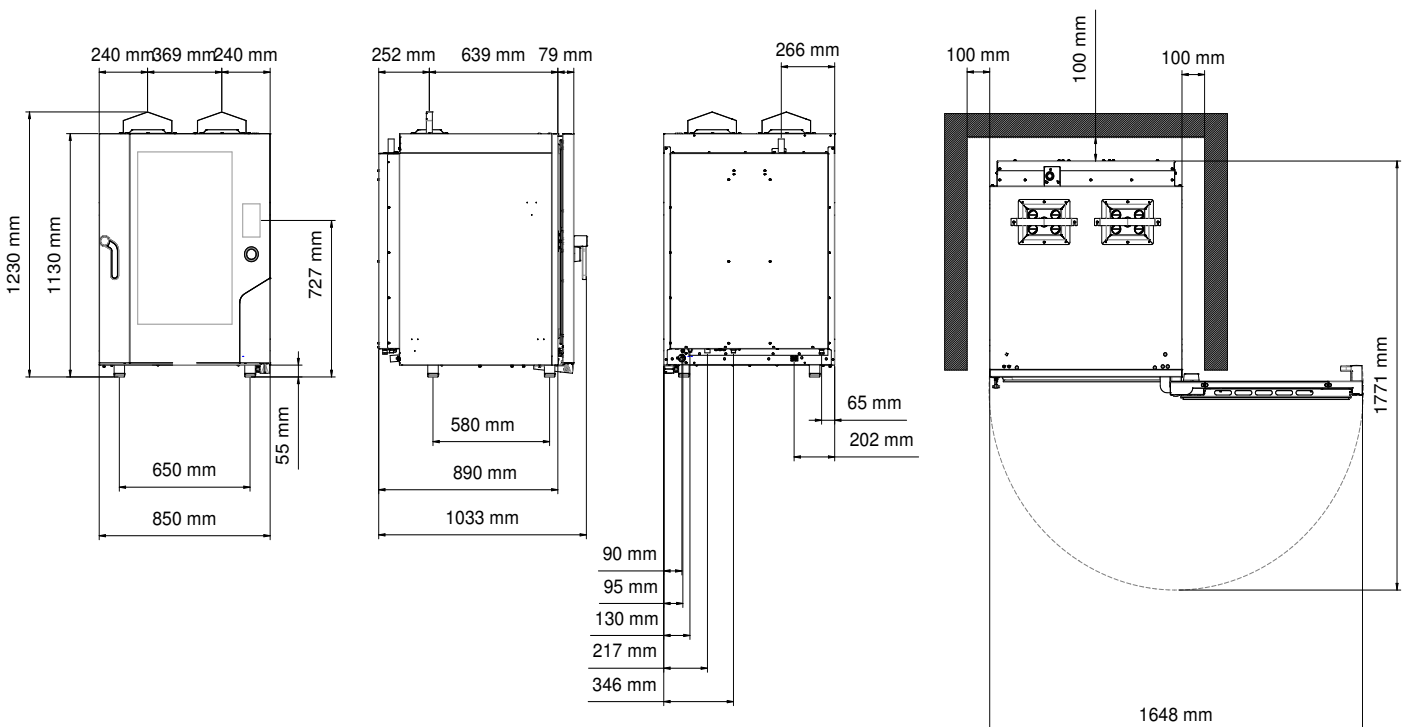

Gas combi oven 10 trays 600 x 400 mm with touch screen

With a capacity of 10 600x400 mm trays, the CHF 1064 TOP GAS oven is the flagship of the new Millennial GAS line. A concentrate of technology, design, and ease of use. Equipped with adjustable feet and door lock at 60°, 90°, 120°, and 180° opening to meet the needs of the professional at all times. Perfect cooking is no longer a mirage, but a perfectly tangible need thanks to the patented Airflowlogic, Humilogic, and Drylogic technologies of the new Millennial line.



Dimensional features

Dimensions (WxDxH mm)	850 x 1035 x 1230
Weight (kg)	158
Distance between rack rails (mm)	80

Electrical features

Thermal supply (kW)	18
Frequency (Hz)	50/60
Voltage (V)	AC 220/230
N° motors	3 bidirectional
Boiler (kW)	/
Protection against water	IPX3

Functional features

Power	Multigas (tested for natural gas)
Capacity	N° 10 trays/grids 600 x 400 mm
Type of cooking	Semistatic + ventilated
Steam	Direct steam controlled by touch screen (10 levels)
Cooking chamber	AISI 304 stainless steel
Temperature	30 - 260 °C
Temperature control	Digital probe thermometer
Control panel	Touch screen
N° programs	500
Programmable cooking steps	10
Pre-heating temperature	180 °C
Pre-heating function	Programmable
Door	Right side opening Ventilated Inspectionable glass
Feet	Adjustable

Equipment

Cardboard box dimensions with pallet (WxDxH mm)	910 x 1090 x 1300 mm
Lateral supports	1dx + 1sx
Cable	Single-Phase [3G 1,5]-L=1600 mm
USB port	
Multipoint core probe cod. MKSCMU	
Support for core probe cod. MKSSC/A	
Automatic washing system integrated	
Condensate collection bowl, with drain on door	
Hinge with door locking for openings adjusted at 60°, 90°, 120°, 180°	
Nozzle for LPG	

Plus

Patented fan guard system Airflowlogic™	
Patented system for direct steam Humilogic™	
Patented system for cooking chamber drying Drylogic™	
Available on request at the order	Left side opening door
Humidity management software	
Wi-Fi communication system	
Knob for quick selection of the touch screen	
Programmable oven start	
N° 40 recipes stored	
Control panel in 42 languages: Arabic, Armenian, Azerbaijani, Bahasa (Indonesia), Bahasa (Malaysia), Bosnian, Bulgarian, Chinese, Croatian, Czech, Danish, Dutch, English, Estonian, Finnish, French, Georgian, German, Greek, Hungarian, Icelandic, Italian, Japanese, Kazakh, Latvian, Lithuanian, Norwegian, Persian (Iran), Philippine, Polish, Portuguese, Romanian, Russian, Serbian, Slovenian, South Korean, Spanish, Swedish, Thai, Turkish, Ukrainian, Vietnamese	
HACCP system	
Adjustable door hinges	
Regulation 2016/426/UE	